

This view is a composite showing:

- Kitchen units and partitions
- Floor bearers
- Corrugated floor sheeting
- Underframe cross members
- Skirt and wheelset positions
- Electrical conduits and drain runs

TYPICAL SECTION C-C

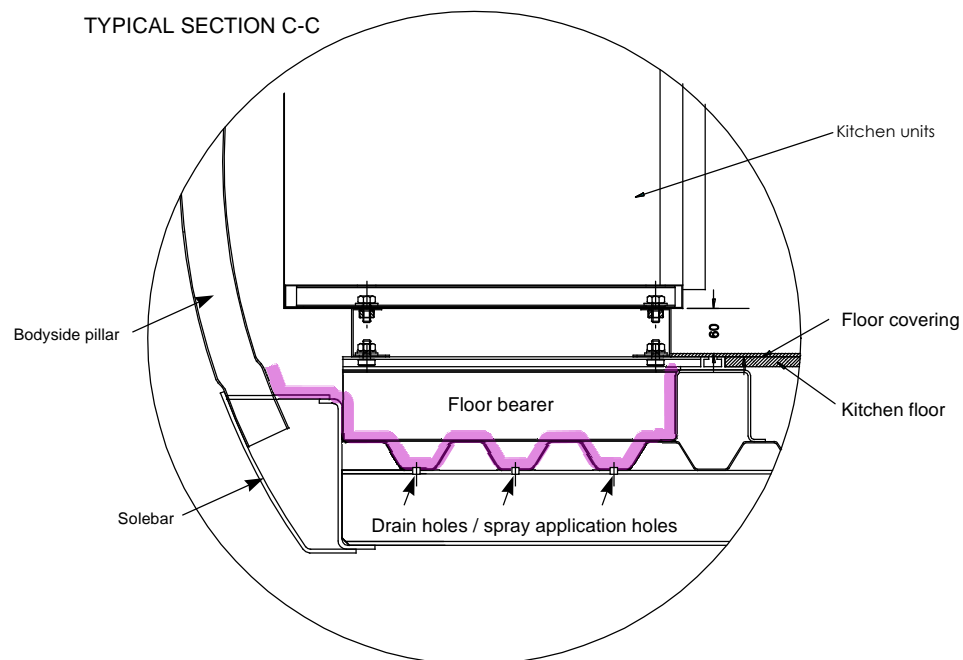

Notes:

1. Pink shaded areas represent target surfaces for corrosion treatment.
2. Holes to be drilled approximately centrally in troughs of corrugations using air operated drill. Where access is limited, drill hole in side of corrugation to intersect with base.
3. Deburr holes internally and externally after drilling.
4. Symbol key:

- 20mm hole, enlarged from existing hole, to be left unplugged
- ⊕ 20mm hole, to be left unplugged
- ⊙ 20mm hole, to plug
- Existing drain pipes or electrical conduits, for reference only.
- Pipe passing through floor panel
- Route of pipe on underframe

Engineering change FMMSA004
Mark 4 SV OH2 corrosion treatment diagram
 Issue 1